

# VRL-500-TA

Vertical Roll Lifter/Tilter

1/18/2005

-Dimensions subject to change  
-Custom configurations available

The VRL-500-TA accepts interchangeable lifting accessories to handle a variety of products. See mandrel and tooling options page for details.

The VRL-500-TA is a vertical roll lifter with tilt assist to allow operator to tip rolls from horizontal to vertical and back and has a maximum load rating of 500lb (227kg). Specific machine capacity is determined using the roll weight and dimensions for each application and may limit capacity to less than maximum load rating.

\*Engineering approval required for each application. Roll dimensions and weights must be provided prior to order

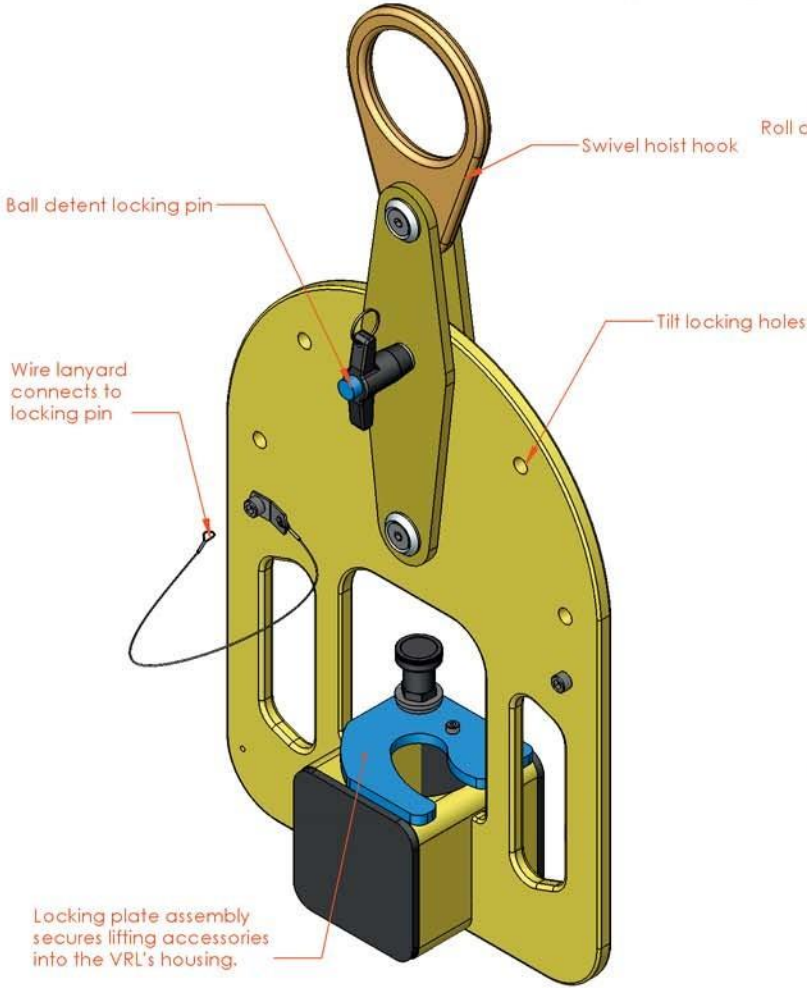

Approx. weight 18lb. (8.2 Kg)  
\*does not include lifting mandrel

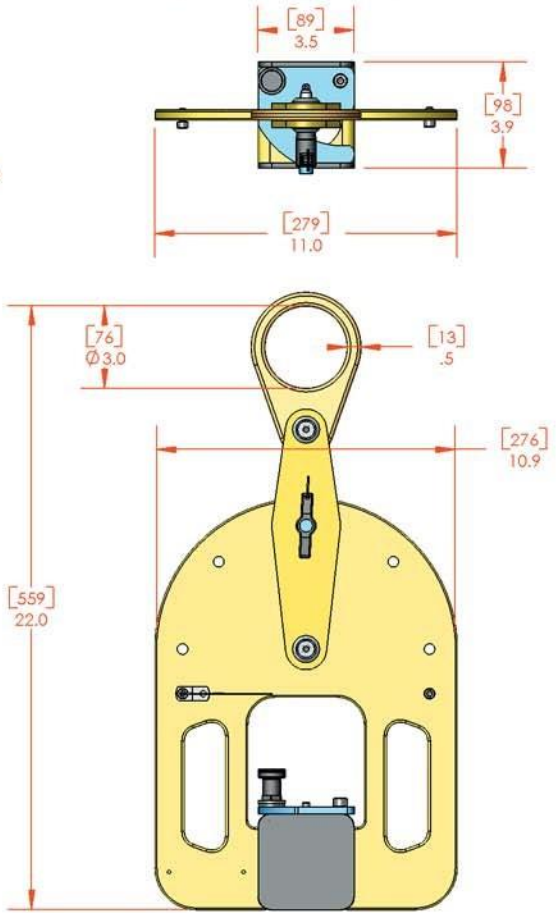

## Roll Tilting Example

Step #1  
Vertical Insertion

Step #2  
Lock Tilt Arm  
in Horz. Position

Step #3  
Lift Roll

Sample roll shown with 3" mandrel  
See capacity chart for roll size tilting limitations.

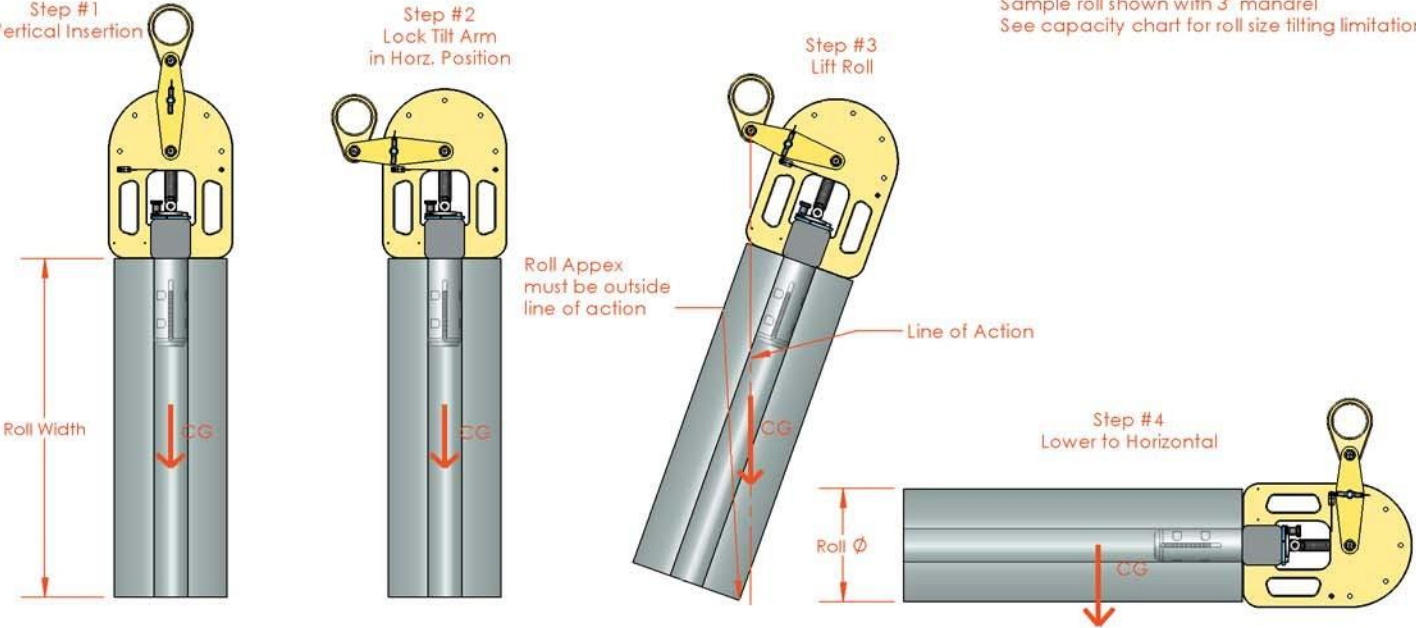

VRL-500-TA Tilt Chart @ 500 lb.

