

# PailPRO Series™

## 5-Gallon Pail Handlers

### Dimensions of Model 83 PailPRO™ 5-Gallon Pail Handler

150 Lb. (68 kg) Capacity

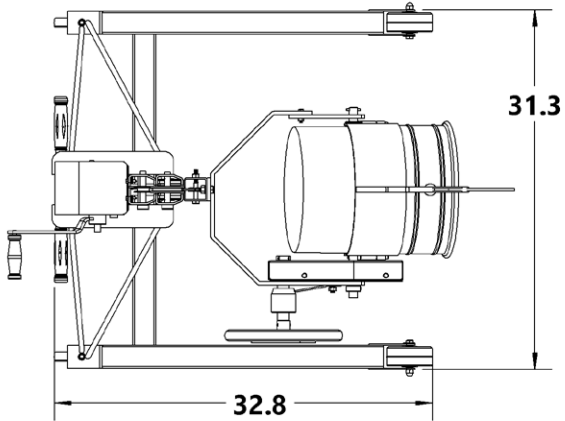

### Dimensions with Counterweight Kit # 3930-P Installed

75 Lb. (34 kg) Capacity

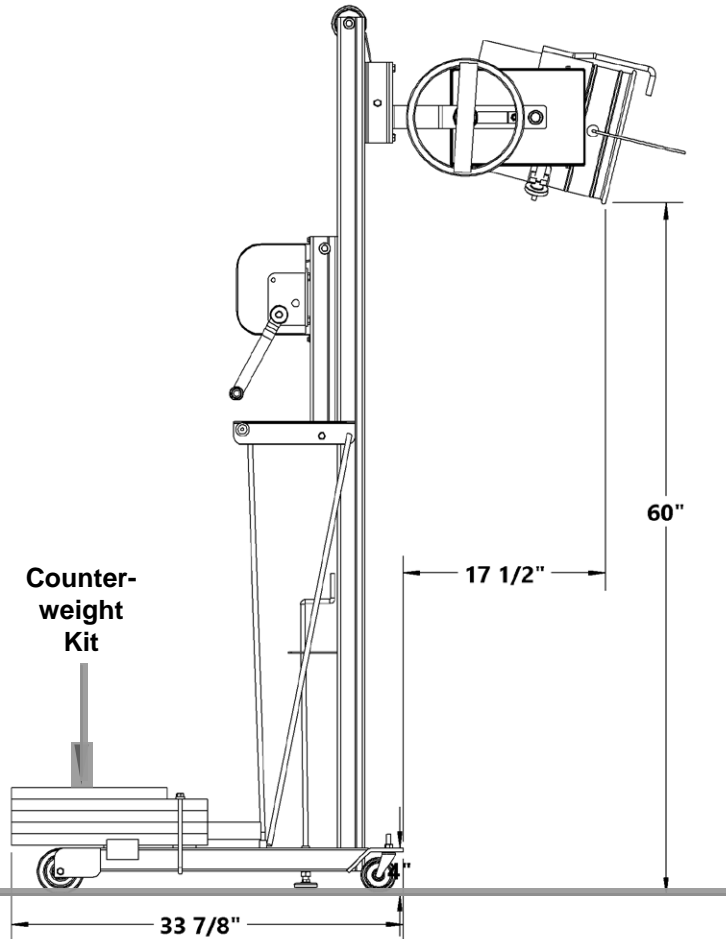
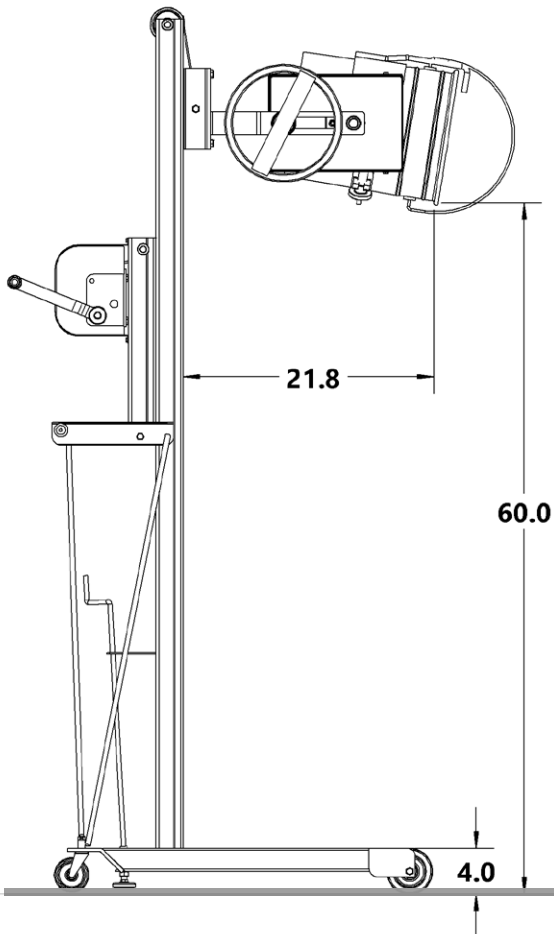
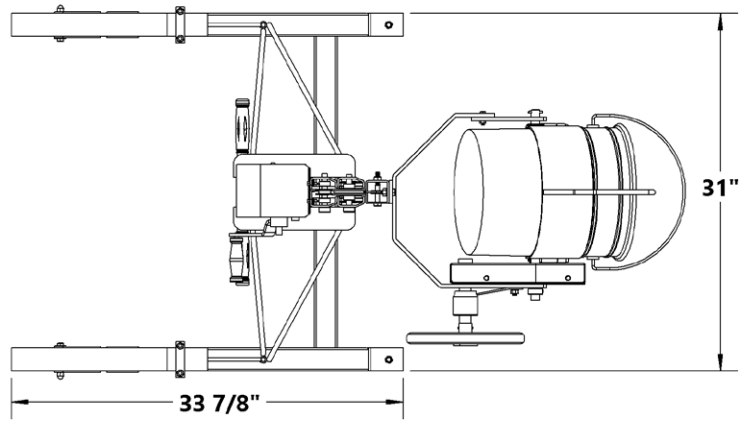

MADE  
IN  
USA

### PailPRO™ Can Tumblers

Rotate your cans or pails to thoroughly blend ingredients with an efficient corner-over-corner mixing action. Perfect for small batches that need mixing, blending, agitating, tumbling, polishing or deburring. The use of ordinary pails can be an economical alternative to special mixing containers or insertion mixers. Tumbling in closed pails eliminates the hazards, worker exposure, and messy cleanup associated with insertion or transferring contents.



Model 1-305-1

Model 2-305-1

The Single Can Tumblers rotate 1 pail (1 to 5 gallons) at a time. The Double Can Tumblers rotate 1 or 2 pails. A 1/4 HP motor rotates the pail at a constant 23 RPM in one direction – the unit does not oscillate or shake the can(s). Only the single phase, 115V units are equipped with an adjustable timer that can be set from 0 to 60 minutes.

Handles Can: 4.5" to 16.5" (11.4 to 42 cm) tall.  
Up to 12.5" (31.75 cm) diameter

Capacity: 100 Lb. (45 kg) per can

Base Dimensions: 28" x 28" (71 x 71 cm)

Domestic Ship Dimensions: L40" W29" H24" (102 x 74 x 61 cm).

Ships Class: 70

Model #	Rotates	Motor Style	Phase	Volts	Hz	Domestic Ship Weight
1-305-1	1 Can	TEFC with Timer	1	115	60	175 Lb. (80 kg)
1-305-1-50	1 Can	TEFC	1	110/220	50	155 Lb. (70 kg)
1-305-1-230	1 Can	TEFC	1	230	60	175 Lb. (80 kg)
1-305-3	1 Can	TEFC	3	230/460	60	175 Lb. (80 kg)
1-305-3-50	1 Can	TEFC	3	220/380/440	50	155 Lb. (70 kg)
1-305-575	1 Can	TEFC	3	575	60	155 Lb. (70 kg)
1-305-A	1 Can	Air Motor				155 Lb. (70 kg)
1-305-E1	1 Can	Explosion-proof *	1	115/230	60	180 Lb. (82 kg)
1-305-E1-50	1 Can	Explosion-proof *	1	110/220	50	180 Lb. (82 kg)
1-305-E3	1 Can	Explosion-proof *	3	230/460	60	180 Lb. (82 kg)
1-305-E3-50	1 Can	Explosion-proof *	3	110/220	50	180 Lb. (82 kg)
1-305-E575	1 Can	Explosion-proof *	3	575	60	180 Lb. (82 kg)
2-305-1	1 or 2 Cans	TEFC with Timer	1	115	60	205 Lb. (93 kg)
2-305-1-50	1 or 2 Cans	TEFC	1	110/220	50	205 Lb. (93 kg)
2-305-1-230	1 or 2 Cans	TEFC	1	230	60	205 Lb. (93 kg)
2-305-3	1 or 2 Cans	TEFC	3	230/460	60	205 Lb. (93 kg)
2-305-3-50	1 or 2 Cans	TEFC	3	220/380/440	50	205 Lb. (93 kg)
2-305-575	1 or 2 Cans	TEFC	3	575	60	205 Lb. (93 kg)
2-305-A	1 or 2 Cans	Air Motor				185 Lb. (84 kg)
2-305-E1	1 or 2 Cans	Explosion-proof *	1	115/230	60	210 Lb. (95 kg)
2-305-E1-50	1 or 2 Cans	Explosion-proof *	1	110/220	50	210 Lb. (95 kg)
2-305-E3	1 or 2 Cans	Explosion-proof *	3	230/460	60	210 Lb. (95 kg)
2-305-E3-50	1 or 2 Cans	Explosion-proof *	3	220/380/440	50	210 Lb. (95 kg)
2-305-E575	1 or 2 Cans	Explosion-proof *	3	575	60	210 Lb. (95 kg)

\* Explosion Proof motors are rated for Class 1 Group D, and for Class 2 Groups F and G.



### PailPRO™ Pail-Karrier

#### Model 85-5

Below-hook Pail-Karrier allows you to use your crane or hoist to lift and control pouring of your 5-gallon plastic or metal pail. Handle a pail 11" to 12" (28 to 30.5 cm) in diameter, and weighing up to 200 Lb. (91 kg).



### PailPRO™ Below-Hook Pail-Lifter

#### Model 92-5

Pail Lifter sized for your 5-gallon (19 liter) pail with 11" to 15" (28 to 38 cm) diameter.

Capacity: 1,000 Lb. (454 kg).

### PailPRO™ Dollies

Specially designed and sized for a 5-gallon (19 liter) pail. Employees can safely and easily move a 5-gallon pail to eliminate repetitive bending and lifting motions. Flat deck design with four rounded corners turned up to hold pail in position. Four 3" (7.6 cm) polyolefin swivel casters.

Handle: pail up to 200 Lb. (91 kg) and 12-5/8" (32 cm) in diameter.

Model 34-5 carbon steel painted blue.

Model 34-5SS type 304 stainless steel for food and pharmaceutical applications. Swivel casters have nickel plated metal components.



### PailPRO™ Pail Heaters

Pail Heaters for 5-gallon metal or plastic pails.

Model 710-5-115 is 115V 550W for metal pail.

Model 710-5-230 is 230V 550W for metal pail.

Model 711-5-115 is 115V 150W for plastic pail.

Model 711-5-230 is 230V 150W for plastic pail.

MADE  
IN  
USA

### PailPRO™ Can Tipper

Ideal for dispensing frequently from 5-gallon cans or pails. A safety lock holds your container. Dispensing height is 10" (25.4 cm). Folds for storage.

Model 15 Can Tipper handles a single pail.

Model 2-15 (shown left) Two-Can Tipper handles 2 pails.



### Model 15-SS (below)

Can Tipper made of type 304 Stainless Steel is suitable for food and pharmaceutical applications, handles one pail