

HRL-330-AL

Horizontal Roll Lifter

1/18/2005

- Dimensions subject to change
- Custom configurations available

The HRL-330-AL accepts interchangeable lifting accessories to handle a variety of products. See mandrel and tooling options page for details.

The HRL-330-AL is a horizontal roll lifter with an automatic leveling system and has a maximum load rating of 330lb (150kg). Specific machine capacity is determined using the roll weight and dimensions for each application and may limit capacity to less than maximum load rating.

- *Unit dimensions and weight are determined at time of order.
- *Engineering approval drawing required prior to fabrication.

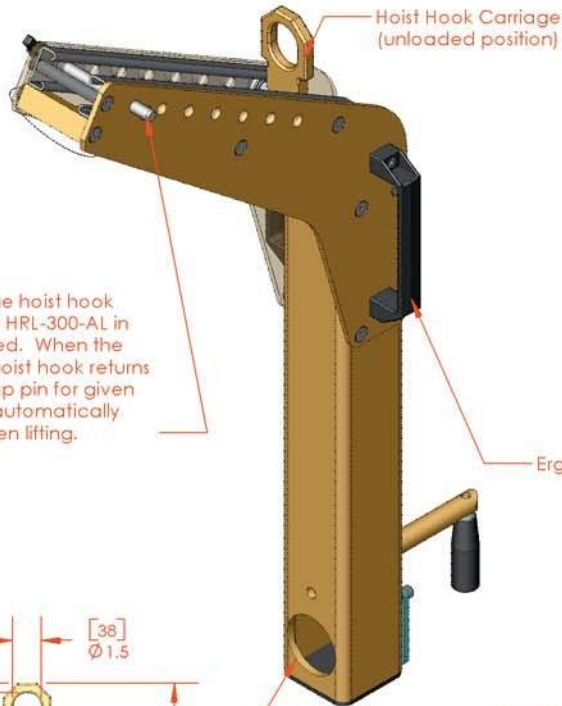

Adjustable stop pin limits the hoist hook carriage travel to keep the HRL-330-AL in a level position while loaded. When the machine is unloaded the hoist hook returns to its home position. Set stop pin for given roll width and the unit will automatically keep the roll horizontal when lifting.

Unit shown weighs 50 lb. (22.7 Kg.)
Handles up to 30" (762mm) dia. rolls

Ergonomic handles

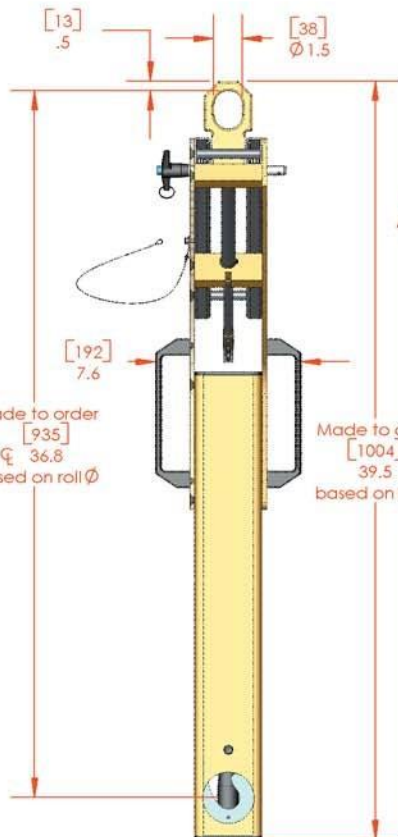

Made to order
[935]
Ø 36.8
based on roll Ø

Made to order
[1004]
39.5
based on roll Ø

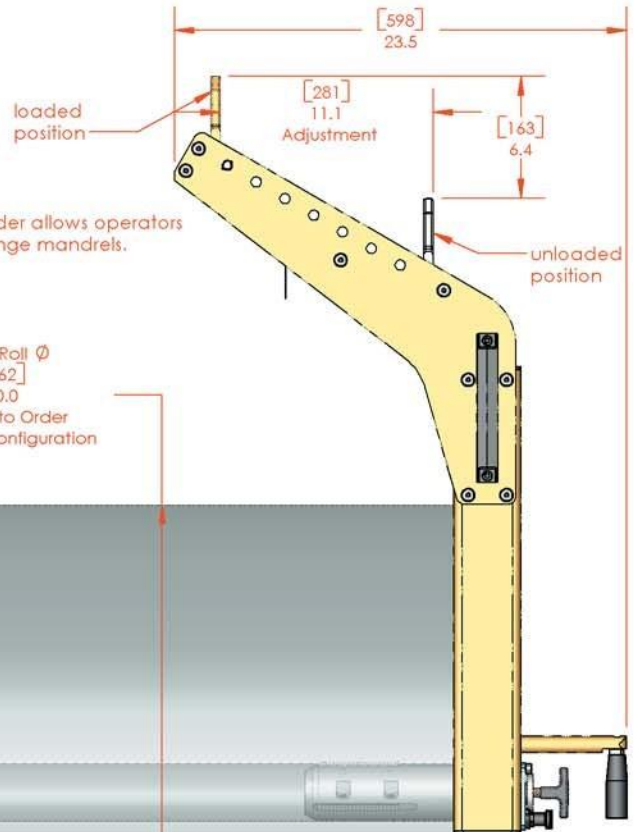

loaded position

[281]
11.1
Adjustment

unloaded position
[163]
6.4

Interchangeable tool holder allows operators to quickly and easily change mandrels.

Max Roll Ø
[762]
30.0
Made to Order
Custom Configuration

Max Roll Width @ 330#
[610]
24.0

*Shown with 3 inch
"T" Handle Mandrel.
Sold Separately