

# HRL-200-P

## Horizontal Roll Lifter

1/18/2005

- Dimensions subject to change
- Custom configurations available

HRL-200-P models are typically made to order. The flexible design allows the unit to be optimized for specific roll sizes.

- \*Unit dimensions and weight are determined at time of order.
- \*Engineering approval drawing required prior to fabrication.

The HRL-200-P is a horizontal roll lifter with a maximum load rating of 200lb (91kg). Specific machine capacity is determined using the roll weight and dimensions for each application and may limit capacity to less than maximum load rating.

- \*Unit dimensions and weight are determined at time of order.
- \*Engineering approval drawing required prior to fabrication.

Adjustable hoist hook position for precise roll leveling

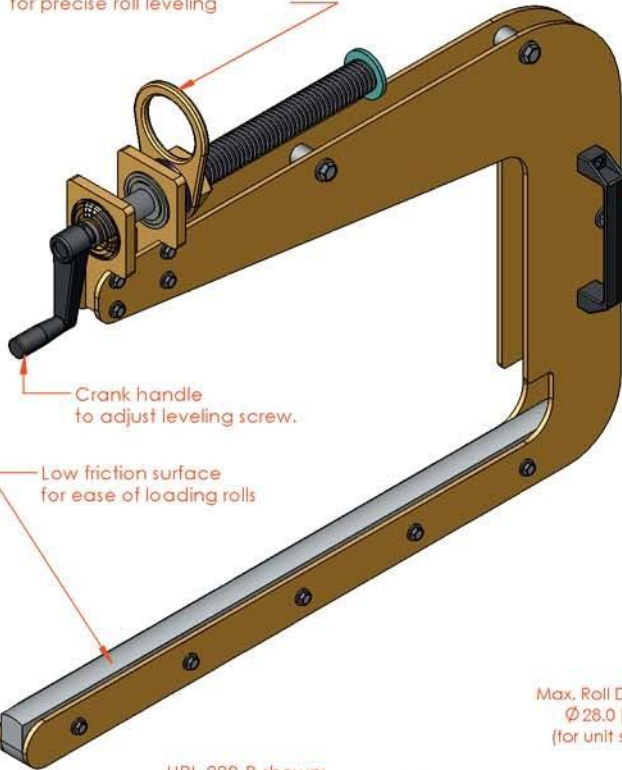

Ergonomic handles

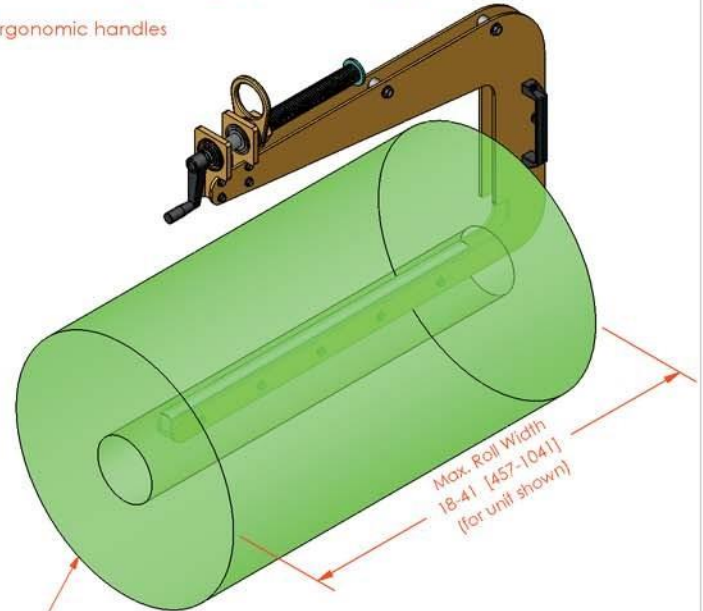

HRL-200-P shown:  
 Unit Weight: 35 lb (16 Kg).  
 Capacity: 200 lb (91 Kg) Roll  
 Roll Width: 18"-41" (457mm-1041mm)  
 Roll Dia: 28" max. (711mm)

