

40" x 48" Pallet Stand
Scale 1:14

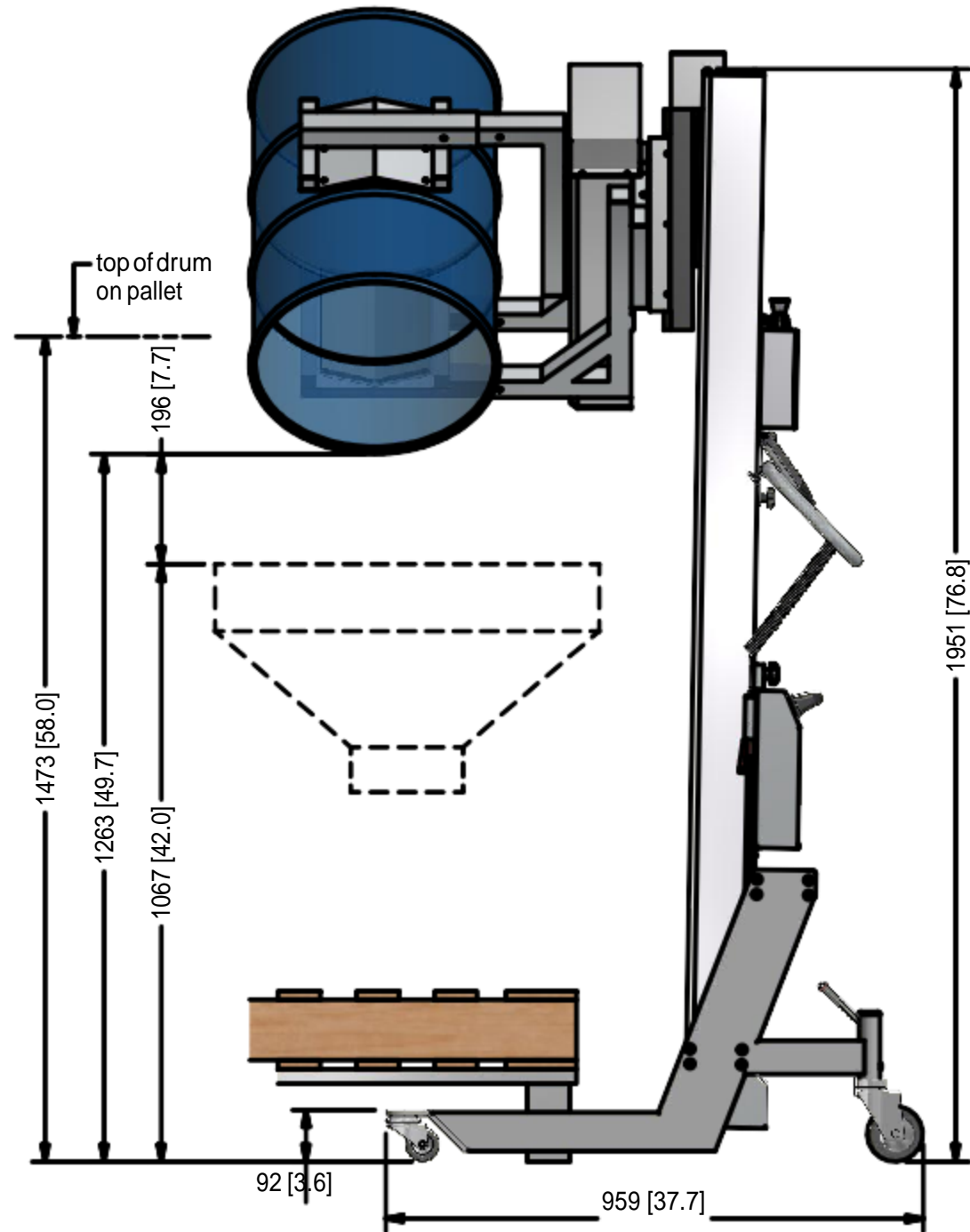

Max. Load 170 lbs.

- Fiber Drums
 - Ø15" x 23" H at 45kg
 - Ø15" x 33" H at 77kg
 - Ø18" x 28" H at 65kg
- Steel Drums
 - Ø17" x 27" H at 37kg

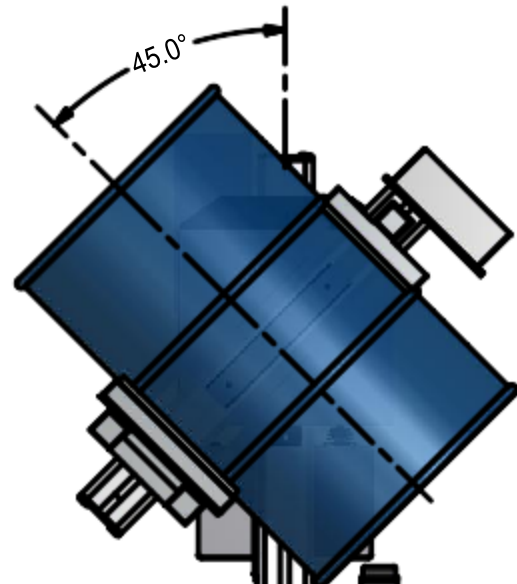
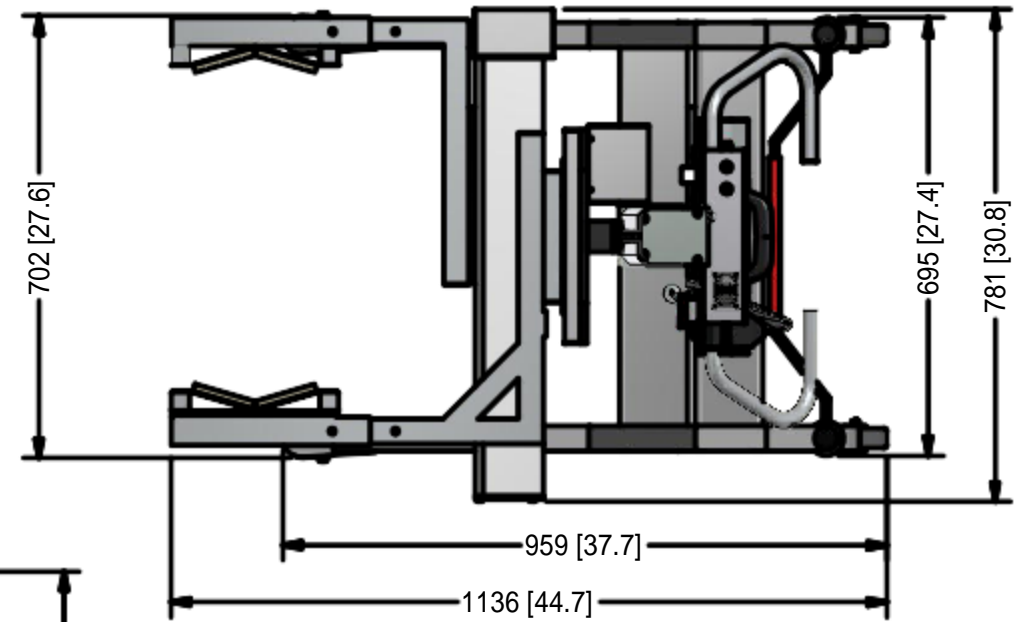
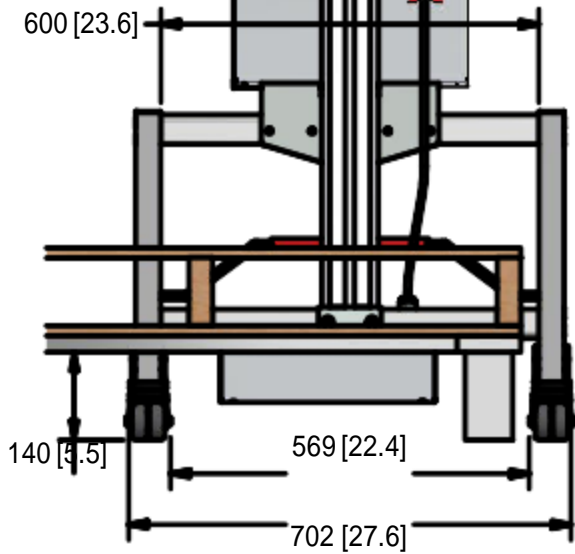
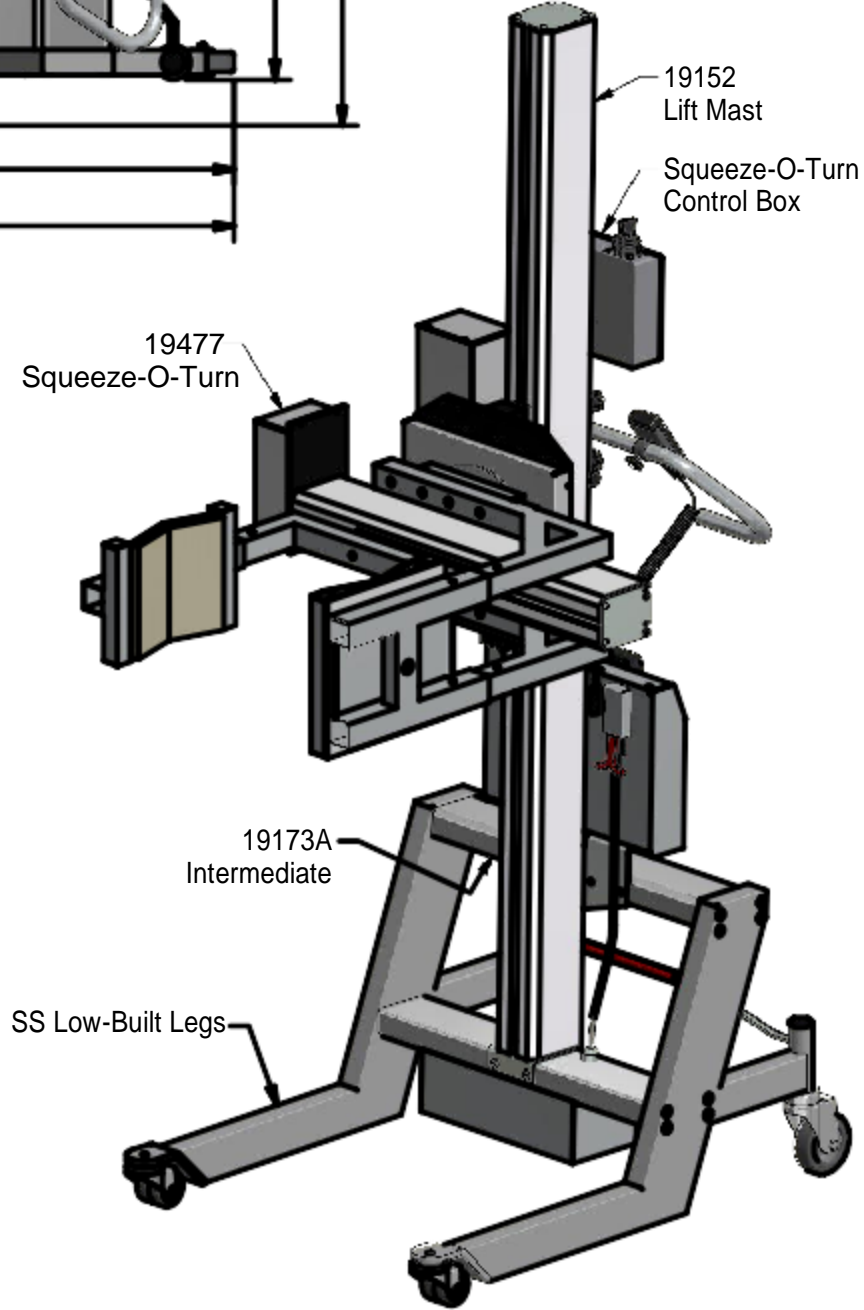

	Tolerances: Unless noted otherwise All outside dimensions	Date: 6/2/2015	Description: 19000 SS Lifter	
	xx +.15% [xxx +.15%] x -.3% [xx -.3%]	xx +.15% [xxx +.15%] x +.3% [xx +.3%] +.8% [x +.8%]	Designed by: JH	with Squeeze-O-Turn
		Drawn by: GH	Project:	
		Scale: 1:12	Dealer:	Drawing No: 50-0840
				Revision: