

# 82H Series Drum Palletizers

Model #	Drum Holder	Features	Motor Type	Motor Control	Domestic Ship Weight
82H	Jaws and brace on sidewall	Hand Pump Lift	-	-	456 Lb.
82H-120	Jaws and brace on sidewall	AC Power Lift	1PH/115V/60Hz, TEFC	Switch, cord and plug	525 Lb.
82H-124	Jaws and brace on sidewall	Air Power Lift	Air Valve	On / Off valve	440 Lb.
82H-125	Jaws and brace on sidewall	Battery Power Lift *	12V DC *	Built-in	512 Lb.
82HM	Jaws and brace on sidewall	<a href="#">spark resistant parts</a> , Hand Pump Lift	-	-	448 Lb.
82HM-124	Jaws and brace on sidewall	<a href="#">spark resistant parts</a> , Air Power Lift	Air Valve	On / Off valve	440 Lb.

\* 12V DC Power Lift includes 12V deep cycle battery, and 100/220V 50/60Hz AC charger.

## Manual Lift Models

Hand Pump to raise drum.

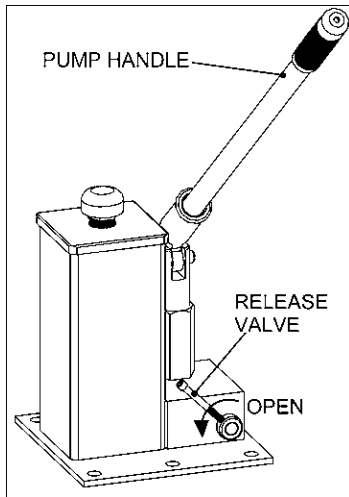

### Hand Pump Lift Control Models 82H and 82HM

It takes 27 pumps of the hand pump to lift a drum to maximum height.

## Models with Power Lift

Models with power lift provide a more ergonomic means of raising your drum.

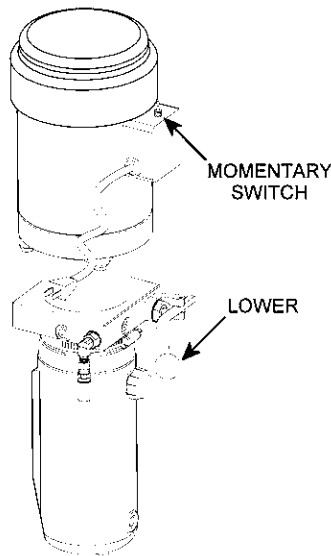

### Electric Power Lift Controls Model 82H-120

Use switch to raise the drum. Lower the drum with manual release valve.

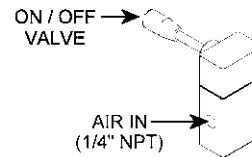

### Air Power Lift Controls Models 82H-124 and 82HM-124

Use on / off valve to raise and lower the drum.

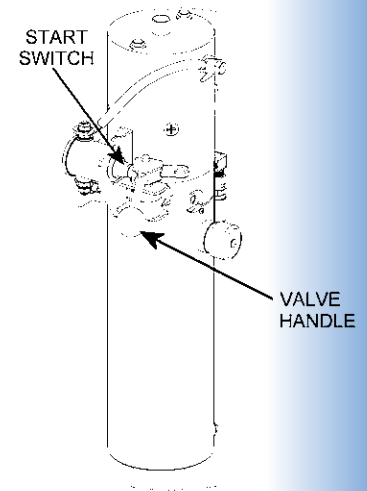

### Battery Power Lift Controls Model 82H-125

Self contained battery power-lift. Use valve to raise and lower the drum. 12V deep cycle battery and separate charger are included.

